

CAL-VAC® / POS-A-SET® Rupture Disc Assemblies

The CAL-VAC / POS-A-SET Rupture Disc Assembly is a highly accurate, double acting pressure relief device designed to protect processing and storage tanks against implosion or overpressure conditions that can occur:

- when too much vacuum is pulled during liquid product withdrawal
 - during hot water or steam cleaning of tanks
 - from development of an abnormal process condition

Both designs relieve pressure settings starting as low as 1" water column differential. The difference in performance of the CAL-VAC Rupture Disc and the POS-A-SET Rupture Disc is how each one is installed (oriented) in the system.

The CAL-VAC Rupture Disc relieves ultra low pressure in the vacuum (negative) pressure direction, while the POS-A-SET Rupture Disc relieves ultra low pressure in the positive pressure direction.



CAL-VAC Assembly



POS-A-SET Assembly



**Continental Disc®
Corporation**

Performance Under Pressure®

CAL-VAC RUPTURE DISC

How a CAL-VAC Rupture Disc Works

The CAL-VAC Rupture Disc is a double acting rupture disc which will relieve an ultra low (inches of water column) vacuum (negative) pressure or a positive pressure condition (psig).

Vacuum Relief *Controlled By A Girdle*

As a negative (vacuum) pressure in the system approaches the burst pressure setting, the girdle becomes loaded until it deflects back past a knifeblade assembly located in the holder inlet. As the girdle passes the knifeblade assembly, the seal is penetrated at the touch point, then cut in a triangular pattern to relieve the negative (vacuum) pressure.

Systems can be operated to within 1" water column for girdle ratings up to 10" water column and up to 90% of the touch point for girdle ratings above 10" water column start relief.

Refer to Table III for available girdle settings.

Positive Pressure Relief *Controlled By A Top Section*

The perforated metal top section, under tension loading, relieves high positive pressure when overpressure in the system occurs. It incorporates CDC's seven hole pattern at the apex of the rupture disc dome. The seven-hole pattern, along with six pre-cut sections, provides a non-fragmenting design. Refer to Table I for minimum and maximum burst ratings of the CAL-VAC Rupture Disc top section.

Additionally the top section's prepunched holes provide optimum flow through the rupture disc when relieving in the negative (vacuum) pressure direction. Consult the factory for flow capacity information.

CAL-VAC Rupture Disc Assembly

The CAL-VAC Rupture Disc has a flat seat design to reduce susceptibility to product buildup and promote easier cleaning to meet FDA requirements. NO MOVING PARTS eliminates the possibility of mechanical malfunction and assures proper operation.

Design features include:

PERFORATED METAL TOP SECTION

...provides positive pressure relief as calculated per standard flow relief for a primary relieving device. The CAL-VAC Rupture Disc will withstand an 80% operating to stamped burst pressure ratio in the positive pressure direction.

RING... installed on the outlet side of the Teflon** seal, provides seat protection for the seal and is used in place of a top section for applications which do not require positive pressure relief.

TEFLON SEAL... distributes pressure uniformly in both the positive and negative (vacuum) directions and eliminates external or internal leakage. An optional B.D.I.*** Alarm Strip is applied to the Teflon seal when the rupture disc is to be incorporated in an alarm system.

A TEFLON SLOT COVER, positioned on the vent side of the seal, protects the Teflon seal from the perforated metal top section.

GIRDLE... of Teflon or stainless steel controls the standard minimum to maximum inches of water column vacuum rating.

CAL-VAC Rupture Disc components are supplied to the user without permanent attachment. Upon negative (vacuum) pressure relief, and when a Teflon girdle is used, the Teflon seal is usually the only component which needs to be replaced. If positive pressure relief occurs, then all component parts (except the holder) must be replaced.

**Teflon is a registered trademark of E.I. du Pont de Nemours and Company used under license.

CAL-VAC HOLDERS

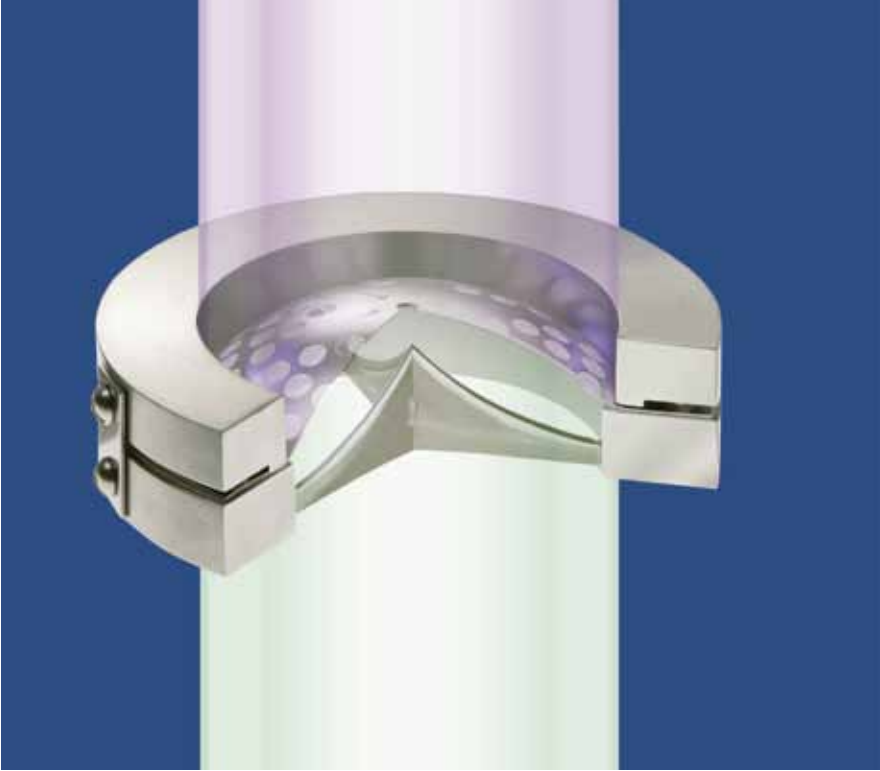

CAL-VAC INSERT HOLDER

The CAL-VAC Insert Holder is designed for installation between ASME, JIS or DIN class flanges as shown in Table V, page 5. It is available in sizes 3" through 12" (80 – 300mm). Locator pins on the holder inlet assure proper rupture disc alignment. A Knifeblade Assembly with PRECISION-HONED EDGES is permanently affixed in the holder inlet to provide maximum vacuum relief. Prior to installation, the CAL-VAC Rupture Disc and holder parts are preassembled using stainless steel preassembly clips.

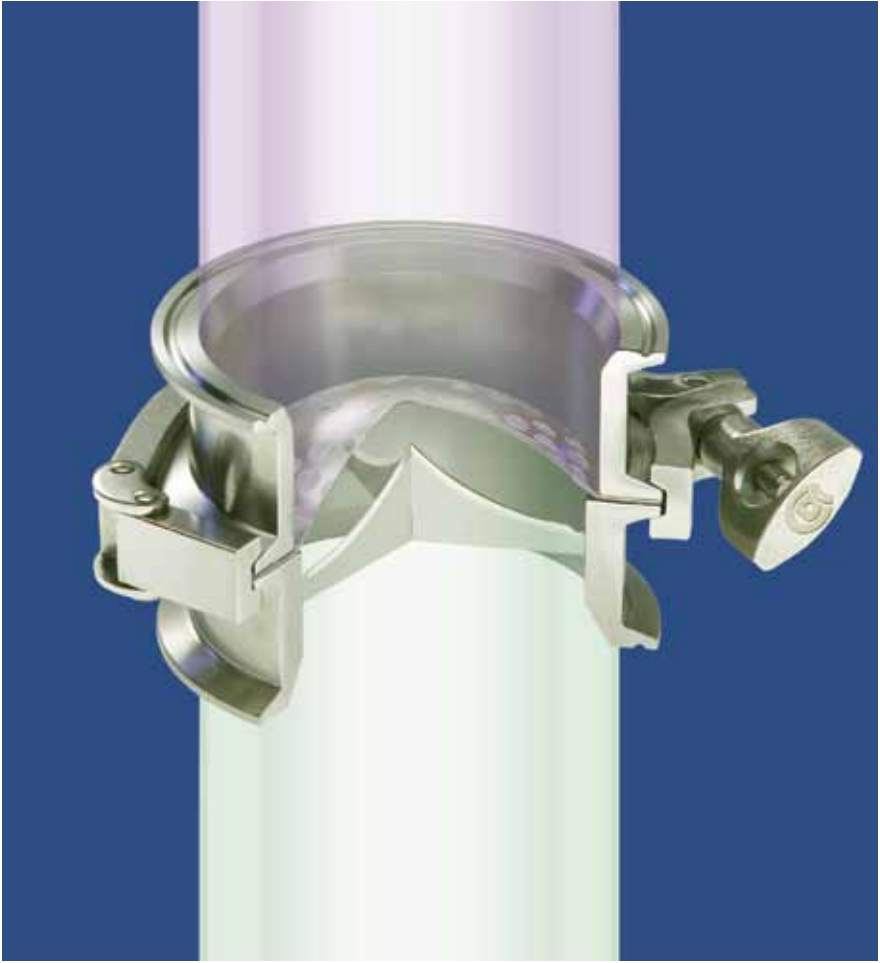
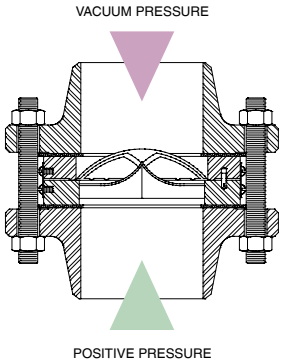

CAL-VAC SANITARY FITTING HOLDER

The CAL-VAC Sanitary Fitting Holder utilizes quick disconnect clamping that provides a secure, leak-tight joint, free of pockets or crevices and permits fast installation, minimizing downtime. A Knifeblade Assembly with PRECISION-HONED EDGES is located in the holder inlet and is designed to provide maximum vacuum relief.

The CAL-VAC Sanitary Fitting Holder is ideally suited for a wide range of applications where contamination and corrosion are hazards. It is designed to comply with the Committee for Food, Drug and Beverage Equipment and is accepted as meeting 3A Sanitary Standards by appropriate committees of the International Association of Milk, Food and Environmental Sanitarians, U.S. Public Health Service and Dairy Industry Committee. The Standard is designated as Serial #60-00 and is available from the International Association of Milk, Food and Environmental Sanitarians, Inc.

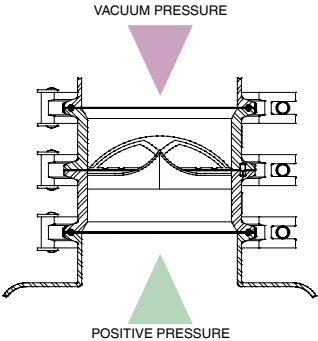

CAL-VAC RUPTURE DISC SPECIFICATIONS

Manufacturing Range / Burst Tolerance

Manufacturing Range is defined as the allowable pressure range within which a rupture disc is rated. It is based upon the customer specified burst pressure. The manufacturing range for the CAL-VAC rupture disc top section varies depending upon the burst rating.

After the top section has been manufactured and tested, it is stamped with the rated burst pressure. The rated (stamped) burst pressure is established by bursting a minimum of two discs and averaging the pressures at which the rupture discs burst. This average is the rated (stamped) burst pressure of the rupture disc.

Tables I and II review Burst Ratings, Manufacturing Range and Burst Tolerance of the CAL-VAC rupture disc top section.

Minimum / Maximum Girdle Rating

The CAL-VAC rupture disc girdle component requires a 6" water column spread from START RELIEF POINT (minimum) to FULL RELIEF POINT (maximum).

Start Relief Point or touch point (minimum) is the rating at which relief begins when the Teflon® seal is pierced by the knifeblade assembly. A Start Relief Point is available from 1" water column to 30" water column, depending on the girdle material selected. See Table III for details.

Full Relief Point (maximum) is the rating 6" water column over the Start Relief Point at which full negative relief opening is obtained.

For example: A 6" CAL-VAC rupture disc required to relieve at 13" water column negative (vacuum) pressure, will have a Start Relief Point (minimum) of 13" water column and a Full Relief Point (maximum) of 19" water column.

Recommended Temperature Limits

The CAL-VAC Rupture Disc can operate in temperature conditions as low as minus 40°F to 400°F (-40° – 204°C) depending upon the type of material chosen for the rupture disc girdle component. Table IV shows the temperature limitations for various rupture disc girdle materials.

Table IV - CAL-VAC Recommended Temperature Limits

Girdle Material	Temperature Limit	
	Minimum	Maximum
Teflon	-40°F / -40°C	150°F / 66°C
316SS	-40°F / -40°C	400°F / 204°C

Table I - CAL-VAC Rupture Disc Top Section Minimum / Maximum Burst Rating at 72°F (22°C)

Nominal Size	Burst Pressure					
	Minimum		Maximum			
			Insert Type Holder		Sanitary Fitting Type Holder	
	psig	barg	psig	barg	psig	barg
3 in 80mm	8	0,552	150	10,3	100	6,89
4 in 100mm	7	0,483	125	8,62	75	5,17
6 in 150mm	4	0,276	100	6,89	50	3,45
8 in 200mm	3	0,207	75	5,17	40	2,76
10 in 250mm	3	0,207	50	3,45	30	2,07
12 in 300mm	2	0,138	40	2,76	N/A*	

* 12" NOT available in sanitary fitting design

Table II - CAL-VAC Rupture Disc Top Section Manufacturing Range / Burst Tolerance at 72°F (22°C)

Specified Burst Pressure Rating		Manufacturing Range		Burst Tolerance
psig	barg	%under	%over	
2 - 5	0,138 - 0,345	-40	+40	±25%
6 - 8	0,414 - 0,552	-40	+40	±20%
9 - 12	0,612 - 0,827	-30	+30	±15%
13 - 14	0,896 - 0,965	-10	+20	±10%
15 - 19	1,03 - 1,31	-10	+20	± 2 psig (0,138 barg)
20 - 40	1,38 - 2,76	-4	+14	±2 psig (0,138 barg)
41 - 50	2,83 - 3,45	-4	+14	±5%
51 - 100	3,52 - 6,89	-4	+10	±5%
101 - 150	7,0 - 10,3	-4	+7	±5%

Table III - CAL-VAC Rupture Disc Girdle Start Relief (minimum) / Full Relief (maximum) Burst Rating at 72°F (22°C)

Nominal Size	Start Relief (minimum) Rating White bar indicates inches of water column Grey bar indicates cm of water column				Full Relief (maximum) Rating Inches of Water Column
	Teflon Girdle		316 SS Girdle		Teflon or 316 SS Girdle
	min	max	min	max	
3 in	1	30	6	30	Plus (+) 6" (15,2 cm) water column from Start Relief (minimum) Rating
80mm	2,54	76,2	15,2	76,2	
4 in	1	30	6	30	
100mm	2,54	76,2	15,2	76,2	
6 in	1	30	6	30	
150mm	2,54	76,2	15,2	76,2	
8 in	1	20	6	30	
200mm	2,54	50,8	15,2	76,2	
10 in	N/A	N/A	6	30	
250mm			15,2	76,2	
12 in	N/A	N/A	6	30	
300mm			15,2	76,2	

CAL-VAC INSERT HOLDER

CAL-VAC Insert Holders are machined from standard materials including carbon steel, 304 SS and 316 SS. Standard knifeblade materials include heat-treated 17-7 PH stainless steel or 316 SS. Consult the factory for availability of other holder or knifeblade materials. Weights and dimensions for this holder are shown in Table V.

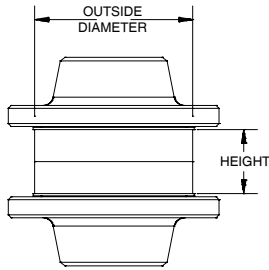

CAL-VAC SANITARY FITTING HOLDER

CAL-VAC Sanitary Fitting Holders are available in sizes 3" through 10" (80 – 250mm) and require a clamp one size larger than the nominal rupture disc size. Two locator pins assure proper rupture disc alignment. See Table VI for holder dimensions and corresponding clamp size.

CAL-VAC Sanitary Fitting Holders are machined from standard materials of 316 or 316L stainless steel. Standard knifeblade material is 316 SS. For availability of other holder or knifeblade materials, consult the factory.

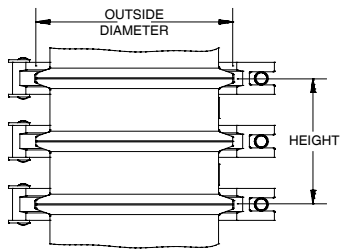

Table V - CAL-VAC Insert Holder Dimensions and Weights

Nominal Size	Maximum Pressure Rating at 72°F (22°C) (psig / barg)	ASME		DIN		JIS		Height (inch / mm)	Weight (lbs / kg)
		Class	Outside Diameter (inch / mm)	Class	Outside Diameter (inch / mm)	Class	Outside Diameter (inch / mm)		
3 in 80mm	150/ 10,4					10	5.16 / 131,0	1.25 / 32	4.2 / 1,9
		150	5.25 / 133,4			16 / 20	5.39 / 137,0	1.25 / 32	4.5 / 2,0
				10 / 40	5.59 / 142,0			1.25 / 32	5.5 / 2,5
4 in 100mm	125/ 8,6			10 / 16	6.38 / 162,0	16 / 20	6.14 / 156,0	1.25 / 32	5.1 / 2,3
		150	6.75 / 171,5				6.38 / 162,0	1.25 / 32	5.9 / 2,7
								1.25 / 32	7.3 / 3,3
6 in 150mm	100/ 6,9			10 / 16	8.54 / 217,0	10	8.54 / 217,0	1.25 / 32	8.9 / 4,0
		150	8.63 / 219,2			10 / 16	9.25 / 235,0	1.25 / 32	9.3 / 4,2
								1.25 / 32	13 / 6,0
8 in 200mm	75/ 5,2			10 / 16	10.71 / 272,0			1.25 / 32	11 / 5,0
		150	10.88 / 276,4					1.25 / 32	12 / 5,4
						16 / 20	11.02 / 280,0	1.25 / 32	14 / 6,4
10 in 250mm	50/ 3,5			10 / 16	12.87 / 327,0			1.5 / 38	20 / 9,1
		150	13.25 / 336,6			10	12.99 / 330,0	1.5 / 38	20 / 9,1
						16 / 20	13.9 / 353,0	1.5 / 38	28 / 13
12 in 300mm	40/ 2,8			10	14.84 / 377,0	10	14.76 / 375,0	1.5 / 38	21 / 9,5
				16	15.08 / 383,0			1.5 / 38	27 / 12
		150	16 / 406,4			16 / 20	15.87 / 403,0	1.5 / 38	33 / 15

Consult factory for availability of other flange classes.

Table VI - CAL-VAC Sanitary Fitting Holder Dimensions and Weights

Nominal Size	Maximum Pressure Rating at 72°F (22°C) (psig / barg)	Outside Diameter (inch / mm)	Height (inch / mm)	Clamp Connection Size	Weight (lbs / kg)
3" / 80mm	100 / 6,89	4.68 / 118,9	3 / 76	4"	4.4 / 2,0
4" / 100mm	75 / 5,17	6.57 / 166,9	4 / 102	6"	15 / 6,8
6" / 150mm	50 / 3,45	8.57 / 217,7	4 / 102	8"	18 / 8,2
8" / 200mm	40 / 2,76	10.57 / 268,5	4.5 / 114	10"	24 / 11
10" / 250mm	80 / 2,07	12.57 / 319,3	4.5 / 114	12"	29 / 13

Consult factory for sanitary fitting holders with custom designed inlet and outlet connections.

POS-A-SET RUPTURE DISC

How a POS-A-SET Rupture Disc Works

The POS-A-SET Rupture Disc is a double acting rupture disc which will relieve an ultra low (inches of water column) positive pressure or a vacuum (negative) pressure condition (psig).

Positive Pressure Relief *Controlled By A Girdle*

As positive pressure in the system approaches the burst pressure setting, the girdle becomes loaded until it deflects back past a knifeblade assembly located in the holder outlet. As the girdle passes the knifeblade assembly, the seal is penetrated at the touch point, then cut in a triangular pattern to relieve the ULTRA-LOW POSITIVE pressure.

Systems can be operated to within 1" water column for girdle ratings up to 10" water column start relief and up to 90% of the minimum positive rating for girdle ratings above 10" water column start relief.

Refer to Table IX for available girdle settings.

Vacuum Relief *Controlled By A Top Section*

The perforated metal top section, under tension loading, relieves negative (vacuum) pressure when vacuum occurs in the system. It incorporates CDC's seven hole pattern at the apex of the rupture disc dome. The seven-hole pattern, along with six pre-cut sections, provides a non-fragmenting design. Refer to Table VII for minimum and maximum burst ratings of the POS-A-SET Rupture Disc top section.

Additionally the top section's prepunched holes provide optimum flow through the rupture disc when relieving in the positive pressure direction. Consult the factory for flow capacity information.

POS-A-SET Rupture Disc Assembly

The POS-A-SET Rupture Disc has a flat seat design to reduce susceptibility to product buildup and promote easier cleaning to meet FDA requirements. NO MOVING PARTS eliminates the possibility of mechanical malfunction and assures proper operation.

Design features include:

GIRDLE... of Teflon or stainless steel controls the standard minimum to maximum inches of water column positive pressure rating.

TEFLON SEAL... distributes pressure uniformly in both the negative (vacuum) and positive directions and eliminates external or internal leakage. An optional B.D.I. Alarm Strip is applied to the Teflon seal when the rupture disc is to be incorporated in an alarm system.

A **TEFLON SLOT COVER**, positioned on the process side of the seal, protects the Teflon seal from the perforated metal top section.

INLET RING... for applications which do not require negative (vacuum) relief, provides seat protection for the Teflon seal.

PERFORATED METAL TOP SECTION ...provides negative (vacuum) pressure relief at a specified rating. The POS-A-SET Rupture Disc will withstand an 80% operating to stamped burst pressure ratio in the negative (vacuum) direction.

POS-A-SET Rupture Disc components are supplied to the user without permanent attachment. Upon positive pressure relief, and when a Teflon girdle is used, the Teflon seal is usually the only component which needs to be replaced. If negative (vacuum) pressure relief occurs, then all component parts (except the holder) must be replaced.

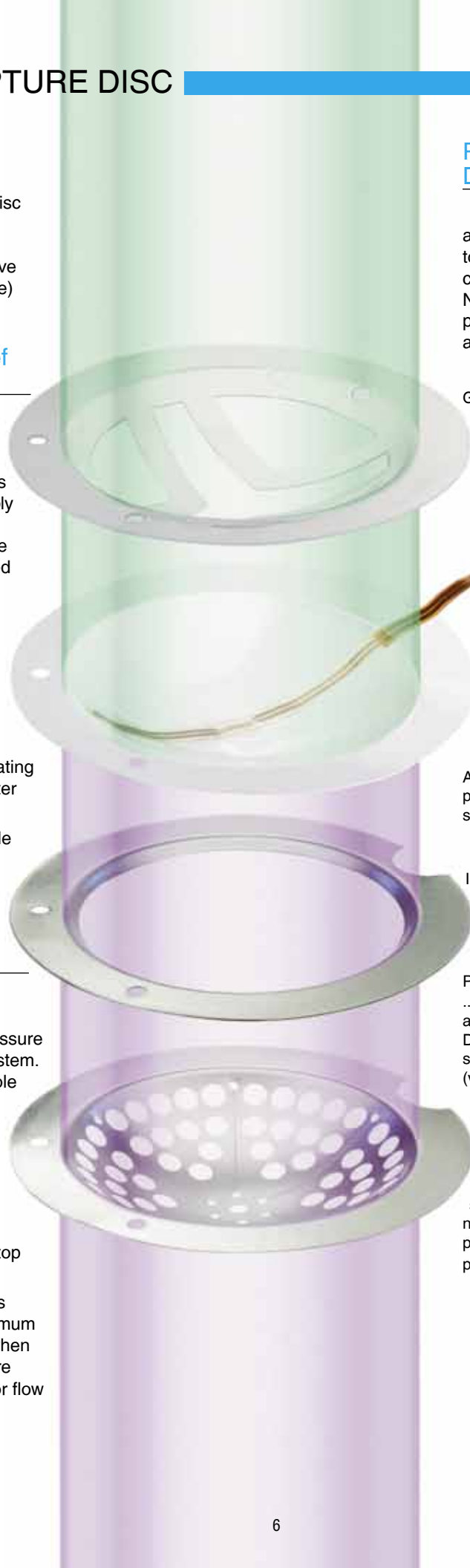

POS-A-SET HOLDERS

POS-A-SET INSERT HOLDER

The POS-A-SET Insert Holder is designed for installation between ASME, JIS or DIN class flanges as shown in Table XI. It is available in sizes 3" through 12" (80 – 300mm). Locator pins on the holder inlet assure proper rupture disc alignment. A Knifeblade Assembly with PRECISION-HONED EDGES is permanently affixed in the holder outlet to provide maximum positive pressure relief. Prior to installation, the POS-A-SET Rupture Disc and holder parts are preassembled using stainless steel preassembly clips.

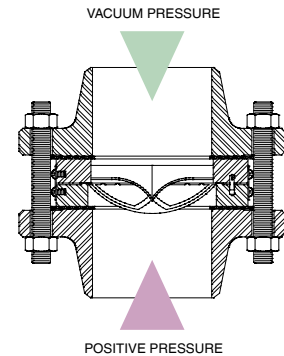
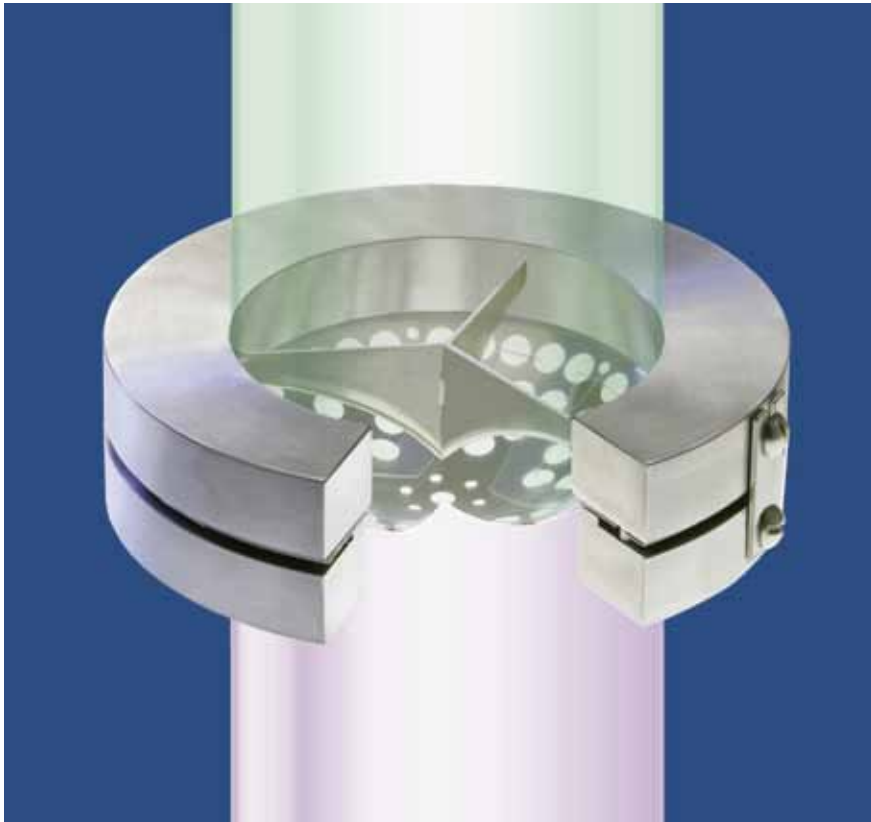

POS-A-SET SANITARY FITTING HOLDER

The POS-A-SET Sanitary Fitting Holder utilizes quick disconnect clamping that provides a secure, leak-tight joint, free of pockets or crevices and permits fast installation, minimizing downtime. A Knifeblade Assembly with PRECISION-HONED EDGES is located in the holder outlet and is designed to provide maximum positive pressure relief.

The POS-A-SET Sanitary Fitting Holder is ideally suited for a wide range of applications where contamination and corrosion are hazards. It is designed to comply with the Committee for Food, Drug and Beverage Equipment and is accepted as meeting 3A Sanitary Standards by appropriate committees of the International Association of Milk, Food and Environmental Sanitarians, U.S. Public Health Service and Dairy Industry Committee. The standard is designated as Serial #60-00 and is available from the International Association of Milk, Food, and Environmental Sanitarians, Inc.

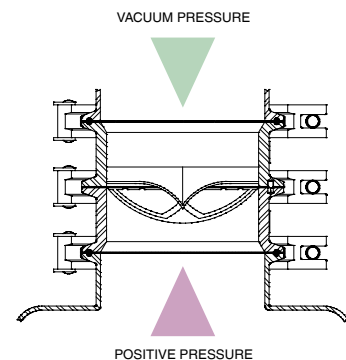

POS-A-SET RUPTURE DISC SPECIFICATIONS

Manufacturing Range / Burst Tolerance

Manufacturing Range is defined as the allowable pressure range within which a rupture disc is rated. It is based upon the customer specified burst pressure. The manufacturing range for the POS-A-SET rupture disc top section varies depending upon the burst rating.

After the top section has been manufactured and tested, it is stamped with the rated burst pressure. The rated (stamped) burst pressure is established by bursting a minimum of two discs and averaging the pressures at which the rupture discs burst. This average is the rated (stamped) burst pressure of the rupture disc.

Tables VII and VIII review Burst Rating, Manufacturing Range and Burst Tolerance of the POS-A-SET top section.

Minimum / Maximum Girdle Rating

The POS-A-SET rupture disc girdle component requires a 6" water column spread from START RELIEF POINT (minimum) to FULL RELIEF POINT (maximum).

Start Relief Point or touch point (minimum) is the rating at which relief begins when the Teflon seal is pierced by the knifeblades.

A Start Relief Point is available from 1" water column to 30" water column, depending on the girdle material selected. See Table IX for details.

Full Relief Point (maximum) is the rating 6" water column over the Start Relief Point at which full positive relief opening is obtained.

For example: A 6" POS-A-SET rupture disc required to relieve at 18" water column positive pressure, will have a Start Relief Point (minimum) of 18" water column and a Full Relief Point (maximum) of 24" water column.

Recommended Temperature Limits

The POS-A-SET Rupture Disc can operate in temperature conditions as low as minus 40°F to 400°F (-40 – 204°C) depending upon the type material chosen for the rupture disc girdle component. Table X shows the temperature limitations for various rupture disc girdle materials.

Table X - POS-A-SET Recommended Temperature Limits

Girdle Material	Temperature Limit	
	Minimum	Maximum
Teflon	-40°F / -40°C	150°F / 66°C
316SS	-40°F / -40°C	400°F / 204°C

Table VII - POS-A-SET Rupture Disc Top Section Minimum / Maximum Burst Rating at 72°F (22°C)

Nominal Size	Burst Pressure					
	Minimum		Maximum			
			Insert Type Holder		Sanitary Fitting Type Holder	
psig	barg	psig	barg	psig	barg	
3 in 80mm	8	0,552	150	10,3	100	6,89
4 in 100mm	7	0,483	125	8,62	75	5,17
6 in 150mm	4	0,276	100	6,89	50	3,45
8 in 200mm	3	0,207	75	5,17	40	2,76
10 in 250mm	3	0,207	50	3,45	30	2,07
12 in 300mm	2	0,138	40	2,76	N/A*	

* 12" NOT available in sanitary fitting design

Table VIII - POS-A-SET Rupture Disc Top Section Manufacturing Range / Burst Tolerance at 72°F (22°C)

Specified Burst Pressure Rating		Manufacturing Range		Burst Tolerance
psig	barg	%under	%over	
2 - 5	0,138 - 0,345	-40	+40	±25%
6 - 8	0,414 - 0,552	-40	+40	±20%
9 - 12	0,612 - 0,827	-30	+30	±15%
13 - 14	0,896 - 0,965	-10	+20	±10%
15 - 19	1,03 - 1,31	-10	+20	± 2 psig (0,138 barg)
20 - 40	1,38 - 2,76	-4	+14	±2 psig (0,138 barg)
41 - 50	2,83 - 3,45	-4	+14	±5%
51 - 100	3,52 - 6,89	-4	+10	±5%
101 - 150	7,0 - 10,3	-4	+7	±5%

Table IX - POS-A-SET Rupture Disc Girdle Start Relief (minimum) / Full Relief (maximum) Burst Rating at 72°F (22°C)

Nominal Size	Start Relief (minimum) Rating White bar indicates inches of water column Grey bar indicates cm of water column				Full Relief (maximum) Rating Inches of Water Column
	Teflon Girdle		316 SS Girdle		
	min	max	min	max	
3 in	1	30	6	30	Plus (+) 6" (15,2 cm) water column from Start Relief (minimum) Rating
80mm	2,54	76,2	15,2	76,2	
4 in	1	30	6	30	
100mm	2,54	76,2	15,2	76,2	
6 in	1	30	6	30	
150mm	2,54	76,2	15,2	76,2	
8 in	1	20	6	30	
200mm	2,54	50,8	15,2	76,2	
10 in	N/A	N/A	6	30	
250mm			15,2	76,2	
12 in	N/A	N/A	6	30	
300mm			15,2	76,2	

POS-A-SET INSERT HOLDER

POS-A-SET Insert Holders are machined from standard materials including carbon steel, 304 SS and 316 SS. Standard knifeblade materials include 17-7PH stainless steel, heat-treated or 316 SS. Consult the factory for availability of other holder or knifeblade materials. Weights and dimensions for this holder are shown in Table XI.

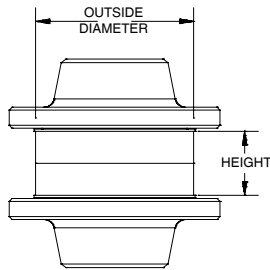

POS-A-SET SANITARY FITTING HOLDER

POS-A-SET Sanitary Fitting Holders are available in sizes 3" through 10" (80 – 250mm) and require a clamp one size larger than the nominal rupture disc size. See Table XII for holder dimensions and corresponding clamp size. The Knifeblade Assembly with PRECISION-HONED EDGES is located in the outlet holder and is designed to provide maximum positive pressure relief. Two locator pins assure proper rupture disc alignment.

POS-A-SET Sanitary Fitting Holders are machined from standard materials of 316 SS or 316 L stainless steel. Standard knifeblade material is 316 SS. For availability of other holder or knifeblade materials, consult the factory.

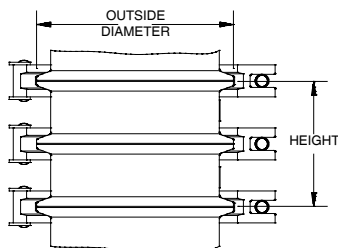

Table XI - POS-A-SET Insert Holder Dimensions and Weights

Nominal Size	Maximum Pressure Rating at 72°F (22°C) (psig / barg)	ASME		DIN		JIS		Height (inch / mm)	Weight (lbs / kg)
		Class	Outside Diameter (inch / mm)	Class	Outside Diameter (inch / mm)	Class	Outside Diameter (inch / mm)		
3 in 80mm	150 / 10,4	150	5.25 / 133,4			10	5.16 / 131,0	1.25 / 32	4.2 / 1,9
						16 / 20	5.39 / 137,0	1.25 / 32	4.9 / 2,2
				10 / 40	5.59 / 142,0			1.25 / 32	5.5 / 2,5
4 in 100mm	125 / 8,6			10 / 16	6.38 / 162,0	16 / 20	6.38 / 162,0	1.25 / 32	5.1 / 2,3
		150	6.75 / 171,5					1.25 / 32	5.9 / 2,7
								1.25 / 32	7.3 / 3,3
6 in 150mm	100 / 6,9			10 / 16	8.54 / 217,0			1.25 / 32	8.9 / 4,0
		150	8.63 / 219,2			10 / 16	9.25 / 235,0	1.25 / 32	9.3 / 4,2
								1.25 / 32	13 / 6,0
8 in 200mm	75 / 5,2			10 / 16	10.71 / 272,0			1.25 / 32	11 / 5,0
		150	10.88 / 276,4					1.25 / 32	12 / 5,4
						16 / 20	11.02 / 280,0	1.25 / 32	13 / 5,9
10 in 250mm	50 / 3,5			10 / 16	12.87 / 327,0			1.5 / 38	20 / 9,1
		150	13.25 / 336,6			10	12.99 / 330,0	1.5 / 38	20 / 9,1
						16 / 20	13.9 / 353,0	1.5 / 38	23 / 10
12 in 300mm	40 / 2,8			10	14.84 / 377,0	10	14.76 / 375,0	1.5 / 38	21 / 9,5
				16	15.08 / 383,0			1.5 / 38	27 / 12
		150	16 / 406,4			16 / 20	15.87 / 403,0	1.5 / 38	33 / 15
							1.5 / 38	34 / 15	

Consult factory for availability of other flange classes.

Table XII - POS-A-SET Sanitary Fitting Holder Dimensions and Weights

Nominal Size	Maximum Pressure Rating at 72°F (22°C) (psig / barg)	Outside Diameter (inch / mm)	Height (inch / mm)	Clamp Connection Size	Weight (lbs / kg)
3" / 80mm	100 / 6,89	4.68 / 118,9	3 / 76	4"	4.4 / 2,0
4" / 100mm	75 / 5,17	6.57 / 166,9	4 / 102	6"	15 / 6,8
6" / 150mm	50 / 3,45	8.57 / 217,7	4 / 102	8"	18 / 8,2
8" / 200mm	40 / 2,76	10.57 / 268,5	4.5 / 114	10"	24 / 11
10" / 250mm	80 / 2,07	12.57 / 319,3	4.5 / 114	12"	29 / 13

Consult factory for sanitary fitting holders with custom designed inlet and outlet connections.

B.D.I.® ALARM SYSTEM

B.D.I.® Alarm System

When immediate notification of pressure or vacuum relief is required, Continental Disc Corporation's B.D.I. (Burst Disc Indicator) Alarm System should be used. Designed for use with any Continental model rupture disc, the B.D.I. Alarm automatically notifies an operator, through audio and/or visual warnings, WHEN and WHERE a rupture disc has relieved positive or vacuum overpressure. This enables the operator to promptly respond to an abnormal process condition or to improper equipment operation or inadequate cleaning.

The heart of the B.D.I. system is the alarm strip which is attached to the Teflon seal. When used with the CAL-VAC or POS-A-SET rupture disc, the B.D.I. Alarm System provides dual warning within one rupture disc.

When vacuum occurs, the CAL-VAC knifeblade assembly (located in the holder inlet) severs the Teflon B.D.I. Alarm Strip, disrupting the electrical current through the alarm strip and initiating a signal to the control panel or other warning devices. If positive overpressure relief occurs, the alarm strip breaks when the perforated metal top section bursts.

In the POS-A-SET design, the knife blade assembly (located in the holder outlet) severs the Teflon B.D.I. Alarm Strip when positive overpressure occurs. If vacuum occurs, the alarm strip breaks when the perforated metal top section bursts.

The B.D.I. Alarm is resistant to most corrosives and can operate at temperatures ranging from -40°F to 400°F (-40° – 204°C). It is available with Factory Mutual approved, intrinsically safe monitors and is computer compatible. Refer to Bulletin 5-7701-5 for complete details about Continental Disc Corporation's B.D.I. Alarm System.

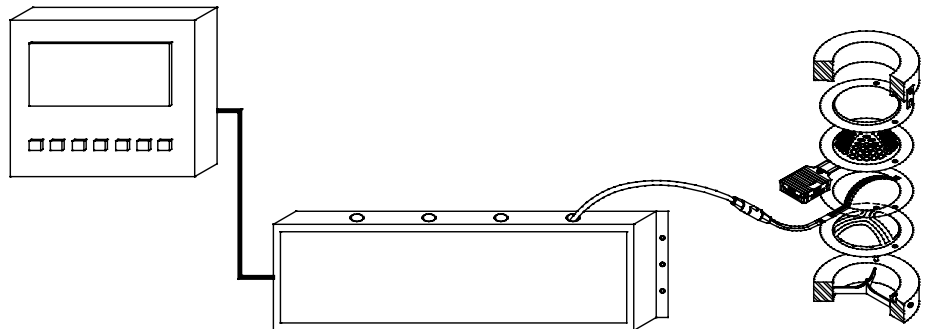

Call, write, or fax the nearest Continental Disc Corporation direct sales office listed on the back to discuss your application requirements or for information on a Continental Disc Corporation representative in your area.

In addition to the full range of Ultra Low overpressure / vacuum relief designs, Continental Disc Corporation, through our Special Products Development Group, can design overpressure relief products for practically any pressure application.

If you have a specialized application, contact our Corporate Headquarters and let our engineers propose a solution specifically designed to meet the requirements of your application.

To facilitate proper product selection, please provide the following specification information:

1. Manufacturing Number: _____ (Please specify when ordering a rupture disc for replacement of a previous Continental Disc Corporation installation.)

 2. Quantity: _____

 3. Size: _____

 4. Style: CAL-VAC
 POS-A-SET

 5. Positive Pressure Setting: _____ @ Service Temperature _____ (° F or °C)

 6. Negative (Vacuum) Pressure Setting: _____ @ Service Temperature _____ (° F or °C)

 7. Holder Style: Insert Bolting Class: _____
 Sanitary Fitting Connection Size: Inlet _____ Outlet _____
-

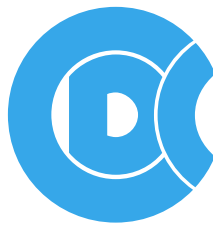

Continental Disc[®] Corporation

Performance Under Pressure[®]



China Manufacture License
Available When Specified



ASME Code Symbol Stamp
Available When Specified



Pressure Equipment Directive
Available When Specified



3A Sanitary Standards Stamp
Available When Specified



**Continental Disc
Corporation**



HEADQUARTERS //

3160 W. Heartland Drive
Liberty, MO 64068 USA
Ph (816) 792 1500 | Fax (816) 792 2277
sales@contdisc.com

contdisc.com

THE NETHERLANDS

Energieweg 20
2382 NJ Zoeterwoude-Rijndijk
The Netherlands
Ph +(31) 71 5412221 | Fax +(31) 71 5414361
cdcnl@contdisc.com

CHINA

Room 910, Tower B, COFCO Plaza
No. 8 JianGuoMenNei Avenue
Beijing (100005), P.R. China
Ph +(86) 10 522 4885 | Fax +(86) 10 6522 2885
cdcchina@contdisc.com

INDIA

423/P/11, Mahagujarat Industrial Estate, Moraiya,
Sarkhej-Bavla Road, Ahmedabad (GJ)
382213 INDIA
Ph +(91) 2717 619 333 | Fax +(86) 10 6522 2885
gcempl@contdisc.com