

# Series 1890

## Pressure Relief Valves

### ASME Section VIII for Air, Steam & Liquid Service



#### Applications include:

- Set pressures to 800 psig.
- Stainless steel body and trim.
- Carbon steel bonnet and cap.
- Flat seats for easy maintenance.

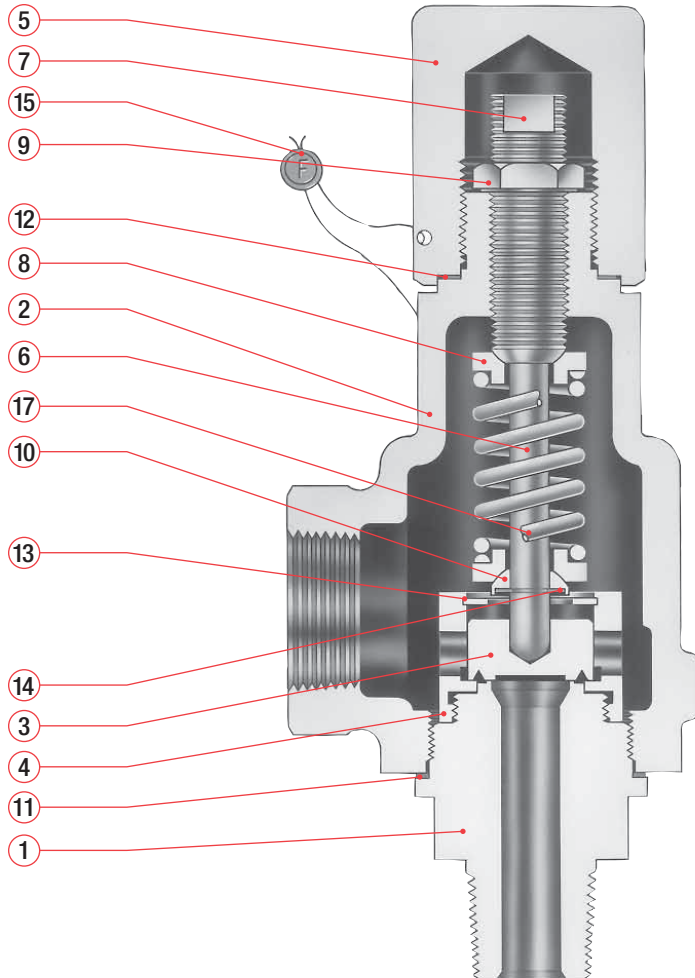

#### Bill of Materials

Item No.	Part Name	Material 1890 & 1892
1	Body	SA-479 Type 316 St. St.
2	Bonnet	SA-216 Gr. WCB Carbon Steel
3	Disc	316 St. St.
4	Guide	Stainless Steel
5	Cap, Plain Screwed	Carbon Steel
6	Stem	Stainless Steel
7	Spring Adj. Screw	Stainless Steel
8	Spring Button	Stainless Steel
9	Jam Nut	Stainless Steel
10	Stem Shoulder	Stainless Steel
11	Body Gasket	316 St. St.
12	Cap Gasket	316 St. St.
13	Lift Stop Ring	Stainless Steel
14	Retaining Ring- Stem Shoulder	Stainless Steel
15	Wire Seal	Stainless Steel Wire/Lead Seal
16	Nameplate (not shown)	Stainless Steel
17	Spring (-20°F to +400°F)	316 St. St.
	Spring (+401°F to +750°F)	Chrome Alloy Rust Proofed



#### Selection Table (Connections: MNPT x FNPT)

Type Number <sup>2</sup>	Service	Valve Size Inlet x Outlet	Maximum Set Pressure, psig <sup>1</sup>		Maximum Set Pressure, barg <sup>1</sup>		Maximum Back Pressures		Materials <sup>1</sup>	
			-20°F to +400°F	+401°F to +750°F	-28.9°C to +204°C	+205°C to +399°C	psig @ 100°F	barg @ 37.8°C	Body / Bonnet	Spring
18902-M20	Air, Steam & Vapor	1/2 x 1	800	800	55	55	50	3.45	316 St. St. / Carbon St.	See Bill of Materials
18903-M20		3/4 x 1								
1890L2-M20	Liquid	1/2 x 1	800	800	55	55	50	3.45	316 St. St. / Carbon St.	See Bill of Materials
1890L3-M20		3/4 x 1								

#### General Notes:

1. For high temperature range (+401°F to 750°F / +205°C to +399°C) change fourth digit of type number from "0" to "2".  
Example: 18902-M20 becomes 18922-M20. Spring changes to Chrome Alloy, Rust Proofed.
2. Type numbers shown designate valves with plain screwed caps. Test lever required for air, steam or hot water service (above 140°F / 60°C).  
For packed lever change the three digit type number suffix from "-M20" to "-M40". Example: 18902-M20 becomes 18902-M40.

# Series 1890 Capacity Tables

ASME Pressure Vessel Code (UV)

Air – 10% Overpressure	
Capacities in Standard Cubic Feet Per Minute at 60° F <sup>1</sup>	
Set Pressure (psig)	Air Capacity
15	51
20	59
30	74
40	92
50	109
60	126
70	144
80	161
90	178
100	195
120	230
140	264
160	299
180	334
200	368
220	403
240	437
260	472
280	506
300	541
320	576
340	610
360	645
380	679
400	714
420	748
440	783
460	817
480	852
500	887
600	1059
700	1232
800	1405

Steam – 10% Overpressure	
Capacities in Lbs. Per Hour at Saturation Temperature <sup>1</sup>	
Set Pressure (psig)	Steam Capacity
15	144
20	166
30	210
40	258
50	307
60	356
70	404
80	453
90	501
100	550
120	647
140	744
160	841
180	938
200	1035
220	1132
240	1229
260	1326
280	1424
300	1521
320	1618
340	1715
360	1812
380	1909
400	2006
420	2103
440	2200
460	2297
480	2394
500	2492
600	2977
700	3462
800	3948

Water – 10% Overpressure	
Capacities in U.S. Gallons Per Minute at 70° F <sup>1,2</sup>	
Set Pressure (psig)	Water Capacity
15	9.3
20	10.6
30	12.7
40	14.6
50	16.3
60	17.9
70	19.4
80	20.7
90	22.0
100	23.1
120	25.4
140	27.4
160	29.3
180	31.1
200	32.7
220	34.3
240	35.9
260	37.3
280	38.8
300	40.1
320	41.4
340	42.7
360	44.0
380	45.2
400	46.3
420	47.5
440	48.6
460	49.7
480	50.8
500	51.8
600	56.8
700	61.3
800	65.5

Actual Orifice Areas				
Inlet Size	Air, Gas & Steam <sup>3</sup>		Liquid <sup>4</sup>	
	sq in	sq mm	sq in	sq mm
1/2" or 3/4"	0.110	71	0.110	71

Dimensions and Weights				
Type Number	A (max) All Cap Constructions	B	C	Approx. Weight Lbs/Kgs
1890	in	1-11/16	2-5/8	3.5
	mm	203	43	1.6

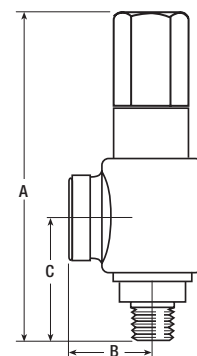

**General Notes:**

- Capacities at 30 psig and below are based on 3 psi overpressure.
- To determine water capacity at 25% overpressure, multiply the capacity at 10% by 1.066.
- For sizing purposes, the coefficient of discharge  $K_d$  is 0.779 for air, gas, steam and vapor.
- For liquid service, use the ASME liquid equation with a coefficient of discharge  $K_d$  equal to 0.529.



10195 Brecksville Road, Brecksville, OH 44141 USA • Telephone: 440-838-7690 • Fax: 440-838-7699 • <http://farris.cwfc.com>

**Facilities:** Brecksville, Ohio, USA; Brantford, Ontario, Edmonton, Alberta, Canada; Bridport, Dorset, UK; Delhi, India; Tianjin, Beijing, China; Dubai, U.A.E.

**Offices Worldwide:** For a listing of our global sales network, visit our website at <http://farris.cwfc.com>.

While this information is presented in good faith and believed to be accurate, Farris Engineering, division of Curtiss-Wright Flow Control Corporation, does not guarantee satisfactory results from reliance on such information. Nothing contained herein is to be construed as a warranty or guarantee, expressed or implied, regarding the performance, merchantability, fitness or any other matter with respect to the products, nor as a recommendation to use any product or process in conflict with any patent. Farris Engineering, division of Curtiss-Wright Flow Control Corporation, reserves the right, without notice, to alter or improve the designs or specifications of the products described herein.